



Phoenix
Digital

OPTICAL COMMUNICATION

For ETHERNET, MODBUS, MODBUS PLUS, and MODICON RIO Networks

Phoenix Digital now provides **MULTIDROP** Fiber Optic Communications for **Ethernet, Modbus™, Modbus Plus™, and Modicon™ Remote I/O** Communication Networks. Optical Communication Modules are available in modular Standalone Enclosures for Panelmount or DIN Rail Installation. . . with integral 120/220 VAC, 24 VDC, or 125 VDC power supplies.

FEATURES

- Fiber Optic Communications. . .
 - Noise Immunity.
 - Intrinsically Safe.
 - Topology Independent (Ring, Bus, Star).
- Dependable Data Communications. . .
 - On-Line Error Checking.
 - Fault Prediction.
 - Fault Location.
 - Fault Tolerant.
 - Redundant Fiber Media.
- Network-Wide Diagnostics. . .
 - Locates Fault and Impending Fault Conditions.
- Ethernet Modules Support TCP/IP Communications. . .
 - IEEE 802.3 CSMA/CD Networks.
- Extended Capacity Fiber Optic Ethernet. . .
 - MULTIDROP** 30+ Fiber Optic Modules on a Single Bus or Ring Network.
- Mix and Match Ethernet 10 Base-T, 10 Base-2, 10 Base-5 Media Options. . .
 - Connect via Twisted Pair, Thin-Net, or Thick-Net Coax
- **UL CLASS I, DIVISION 2 RATING** on all DIN Rail, Standalone Modules
- Selectable Wavelengths. . .
 - 850 nm, 1300 nm, 1550 nm.



- Compatible with Both Singlemode and Multimode Fiber, and with Industrial Fiber.
- Short or Long Distance. . .
 - 6 Feet (2 Meters) to 6 Miles (10 Kilometers) Apart - Multimode Operation.
 - Over 16 Miles (25 Kilometers) Apart - Singlemode Operation.
- Ruggedized Industrial Fiber Optic Cable. . .
 - Available only from Phoenix Digital.
- Compatible with Phoenix Digital's family of **MODBUS PORT EXPANDER PLUS** Multi-Master Multiplexers, Network Servers, and Communication Controllers

DESCRIPTION

Phoenix Digital's family of Optical Communication Modules for Ethernet, Modbus, Modbus Plus, and Modicon Remote I/O networks provide the most

advanced, comprehensive, fiber optic communication capabilities on the market today. Phoenix Digital's fiber optic modules provide optical communication media, transparent to the communication protocol and configurable for distribution by the user in ring, bus, star, tree, or point-to-point network installations. Fiber optic cable is now the media of preference for harsh industrial network environments due to the inherent benefits of high reliability, electrical noise immunity, and intrinsic safety. Phoenix Digital's fiber optic modules provide continuous on-line error checking for jitter, pulsewidth distortion, carrier symmetry, and optical signal strength. All of this, together with comprehensive self-test diagnostics, optimizes the overall integrity of Ethernet, Modbus, Modbus Plus, and Modicon Remote I/O communication networks at-large, providing Dependable Data Communications.

Optical communication network options include features not found in even the most expensive communication network installations:

- On-line Diagnostic Monitoring.
- Self Healing Communication Recovery.
- In-line Signal Monitoring.
- Locates Fault and Impending Fault Conditions.
- Ethernet Modules Fully Compatible with IEEE 802.3.
- Connect over 30 Ethernet Fiber Optic Modules on a Single Multidrop Bus or Redundant Ring Network.
- Each Ethernet Module Provides Integral Hub Functionality... Extra Ports for On-Line Programming, Monitoring, and Diagnostics.
- UL Class I, Division 2 Rating on all Ethernet DIN Rail, Standalone Fiber Optic Modules.
- Ethernet, Modbus, Modbus Plus, and Modicon Remote I/O Modules are Fully Compatible with Network Protocols.
- Full Duplex Modbus Communication.
- Modbus Modules Compatible with

Phoenix Digital's complete line of Modbus Port Expanders, Network Servers, and Communication Controllers.

- Annunciation of Low Signal Level.
- Wavelength Selection.
- Extended Communication Distances.

Phoenix Digital's fiber optic modules may be used together in the same physical network to connect Modicon PLCs, I/O Chassis, Host Computers, Honeywell DCS, etc. Phoenix Digital makes all of this possible, in the price range of a conventional communication modem, through application of its patented self healing communication switch and advanced optical technologies.

OPERATION

FAULT PREDICTIVE... Phoenix Digital's fiber optic modules provide fault prediction through diagnostic monitoring and detection of impending communication failures resulting from gradual degradation of the communication link itself. The fiber optic modules monitor for impending fault conditions by continuously measuring the actual in-line signal strength (optical power) of the data communications at the receive data inputs on the module. The fiber modules continuously compare these actual in-line measurements to preset optical power reference thresholds. If the actual in-line data communication signal strength degrades below these power thresholds the fiber modules will detect and annunciate the impending failure condition via indicators on the front of the module. Phoenix Digital's fiber optic modules also provide hardwired diagnostic outputs (discrete and analog) for detecting and locating impending fault conditions, and for on-line optical power measurement. Thus, communication network status is continuously monitored, and impending failure conditions are annunciated and located before the communication failure actually occurs. This enables maintenance personnel to perform Predictive Maintenance on fiber optic Ethernet, Modbus, Modbus Plus, and Modicon Remote I/O communication networks at-large!

FAULT MANAGEMENT... Phoenix Digital's fiber

optic modules provide fault tolerant, self healing communications through diagnostic monitoring of the communication signal waveforms at each node on the network, and ultra-high speed detection and isolation of points of communication failure anywhere on the network. The fiber optic modules self heal around communication failures in ring, bus, star, tree, or point-to-point network configurations. They automatically redirect network traffic around points of failure until the failure conditions are corrected, and then automatically restore the communication network to its original traffic patterns. Thus, communication continuity is unconditionally maintained by the fiber modules in the event of either node or media failure! In addition, the Phoenix Digital's fiber modules provide diagnostic outputs to locate network fault conditions, enabling maintenance personnel to splice/terminate/replace fiber media, add/delete nodes, etc. on-line, without disrupting network communications! All of this is transparent to the operation of Ethernet, Modbus, Modbus Plus, and Modicon Remote I/O networks.

INTERACTIVE DIAGNOSTICS... Phoenix Digital's fiber optic modules provide advanced, system-level interactive diagnostics. These diagnostics may be used to assist in troubleshooting a wide variety of network problems:

- Detect and Locate Fault Conditions Throughout the Network.
- Trap-and-Hold, and Locate Intermittent Communication Failures.
- Detect and Locate Impending Fault Conditions Throughout the Network.

These advanced diagnostics provide the user with a powerful set of tools, greatly simplifying network start-up and on-line maintenance of Ethernet, Modbus, Modbus Plus, and Modicon Remote I/O networks.

EXTENDED DISTANCES... Phoenix Digital's fiber optic modules provide optional wavelength selection for extended distance applications. The economical 850 nanometer

wavelength may be selected for data communication networks with less than 12,000 feet (3,650 meters) between nodes. The higher performance 1300 and 1550 nanometer multimode wavelengths may be selected for longer distance applications, extending communication distances between nodes to over 6 miles (10 kilometers). The 1300 and 1550 nanometer singlemode wavelengths may be selected for extended distance applications, extending communication distances between Modbus, Modbus Plus, and Modicon Remote I/O nodes to over 16 miles (25 kilometers)! (Consult the factory for long distance Ethernet networks exceeding 2 miles/3 Km.)

INSTALLATION

Phoenix Digital's Ethernet, Modbus, Modbus Plus, and Modicon Remote I/O Modules are available in modular Panelmount, Industrial Enclosures. Ethernet Fiber Optic Modules are also available in modular DIN Rail, Industrial Enclosures. Modbus devices may be cabled directly to Phoenix Digital fiber optic modules using EIA standard Modbus cables, Modbus Plus devices using twisted pair wire, and Modicon Remote I/O devices using RG-6/U or RG-11/U coax cable.

Phoenix Digital's fiber optic modules may be interconnected on the fiber optic network in an active bus configuration, using either multimode or singlemode fiber optic cable (See Figure on Page 6.). Channel A Receive Data inputs and Transmit Data outputs should be interconnected sequentially from fiber module to fiber module in one direction, and Channel B Receive and Transmit Data inputs and outputs interconnected sequentially in the opposite direction. This configuration may be made fault tolerant by cross-connecting end-to-end Channel A (Ch A Transmit to Ch A Receive) and Channel B (Ch B Transmit to Ch B Receive) on the fiber optic modules on either end of the active bus. (See Figures on Pages 7 and 8.). This effectively transforms it into a counter-rotating ring Ethernet, Modbus, Modbus Plus, and Modicon Remote I/O network configuration, without requiring any other action by the user.

ORDERING INFORMATION

Model Number ⁽¹⁾	Description
OCM-ETH ⁽²⁾	ETHERNET Optical Communication Module
OCM-MOD	MODBUS Optical Communication Module
OCM-MDP	MODBUS PLUS Optical Communication Module
OCM-MRI	MODICON Remote I/O Optical Communication Module
OCX-ETH ^(2, 3)	ETHERNET Optical Communication Module
OCM-CBL-A1-10	Ethernet 10 Base-T PLC to OCM/OCX(J1) Interconnect Cable (10 ft/3 mtr)
OCX-CBL-A1-10	Ethernet 10 Base-T PLC to OCX(J2) Interconnect Cable (10 ft/3 mtr)
OCM-AUI-A1	Ethernet 10 Base-T Transceiver

- (1) Add suffix “-85” for 12,000 feet/3,650 meters between nodes (850 nm Multimode Wavelength).
 Add suffix “-13” for 32,000 feet/10 kilometers between nodes (1300 nm Multimode Wavelength).
 Add suffix “-15” for 43,000 feet/13 kilometers between nodes (1550 nm Multimode Wavelength).
 Add suffix “-P” to OCM modules for Panelmount, Standalone Module Enclosure.
 Add suffix “-R” to OCX modules for DIN Rail, Standalone Module Enclosure.
 (OCX-ETH modules only.)
 Add suffix “-D” for Real Time Diagnostic Option. (Required for OCX Class I, Div 2 Rating.)
 Add suffix “-ST” for ST Fiber Optic Connector Style.
 Add suffix “-SMA” for SMA Fiber Optic Connector Style. (Available only with the 850 Nanometer Wavelength.)
 Add suffix “-24V” for 24 VDC Operation.
 Add suffix “-125V” for 125 VDC Operation.
 Add suffix “-ACV” for 120/220 VAC Operation.
 Add suffix “-A1” to OCM-ETH and OCX-ETH Modules for 10 Base-T Operation. (Two “-A1” suffixes may be added to OCM-ETH and OCX-ETH model numbers for dual, integral 10 Base-T Transceiver Operation.)
 Add suffix “-A2” to OCM-ETH and OCX-ETH Modules for 10 Base-2 Operation.
 Add suffix “-EXT” for Networks with 10 or More OCM-ETH and/or OCX-ETH Modules.
 Add suffix “-SM” for Singlemode Operation. (Available with 1300 Nanometer Wavelength, 1550 Nanometer Wavelength, and ST Connector Options Only.)
 Add suffix “-422” to OCM-MOD Modules for RS-422 Modbus Communications.
 Add suffix “-485” to OCM-MOD Modules for RS-485 Modbus Communications.
 Add suffix “-FD” to OCM-MOD Modules for Full Duplex, Point-to-Point Communications.
- (2) Consult the factory for more information on Ethernet communication networks with distances over 2 miles/3 kilometers.
- (3) OCX-ETH modules are rated for use in Class I, Division 2 Hazardous Locations.

Consult the factory for additional information on fiber optic modules for other Open Standard Networks; other Open and Proprietary Control Networks; 19” Rackmount/Panelmount Modems; Industrial Fiber Optic Cable (indoor, outdoor, aerial, burial, etc.); and **MODBUS PORT EXPANDERS**, multiplexers, network servers, and communication controllers for MODBUS networks.

SPECIFICATIONS

Fiber Optic Cable Type	: Multimode or Singlemode
Mating Connector	: ST or SMA
Transmit Launch Power	: -15 dbm (Typical, Multimode); -18 dbm (Singlemode)
Receive Sensitivity	: -32 dbm
Power Supply	: 120/220 VAC, 24 VDC, or 125 VDC.... 10 to 15 Watts
Environmental	
Operating Temperature	: 0° to 60° C (32° to 140° F)
Storage Temperature	: -40° to 85° C (-40° to 185° F)
Relative Humidity	: 0 to 95% RH, non-condensing
Dimensions	
Panelmount, Standalone Modules for Modbus, Modbus Plus, RIO	: 10.38" H x 3.50" W x 7.00" D (26.36cm H x 8.90cm W x 17.78cm D)
Panelmount, Standalone Modules for Ethernet	: 10.38" H x 3.50" W x 6.14" D (26.36cm H x 8.90cm W x 15.60cm D)
DIN Rail, Standalone Modules for Ethernet	: 6.10" H x 3.10" W x 5.50" D (15.49cm H x 7.87cm W x 13.97cm D)
Hazardous Location Approval	: UL AND UL/C Class I, Div 2 Groups A, B, C, D (All OCX modules have the US and Canadian UL Mark for use in Class I Div 2 Groups A, B, C, and D Hazardous Locations.)
European Union Directives	: CE

INDUSTRIAL FIBER OPTIC CABLE

Phoenix Digital provides fiber optic cable specifically designed for rugged industrial applications. IMPORTANT FEATURES include the following:

- **INDUSTRIAL PACKAGING OPTIONS...**
 - Rugged Industrial Construction - Life Expectancy Exceeds 20 Years
 - Extended Temperature and Humidity Range
 - Oil, Chemical, Moisture, Abrasion, and UV Sunlight Resistant
 - Riser Rated (OFNR) and Plenum Rated (OFNP)
- **WIDE VARIETY OF INSTALLATION OPTIONS...**
 - Gel Filled Loose Tube Construction for both Indoor and Outdoor Installation
 - Self Supporting, All Dielectric Cable for Aerial Installation
 - Direct Burial, Armored Cable for Underground Installation
 - Ultra Strong, Non-Armored Cable for Deep Mine Applications
 - Low Smoke, Zero Halogen Cable for Premise Installation
- When Phoenix Digital provides both the FIBER OPTIC MODULES and the FIBER OPTIC CABLE it warrants network physical layer compatibility!

Visit our WEBSITE today at “www.phoenixdigitalcorp.com” for Fiber Optic Cable Data Sheets with Detailed Technical Specifications and Complete Ordering Information.

MODBUS ACTIVE BUS CONFIGURATION

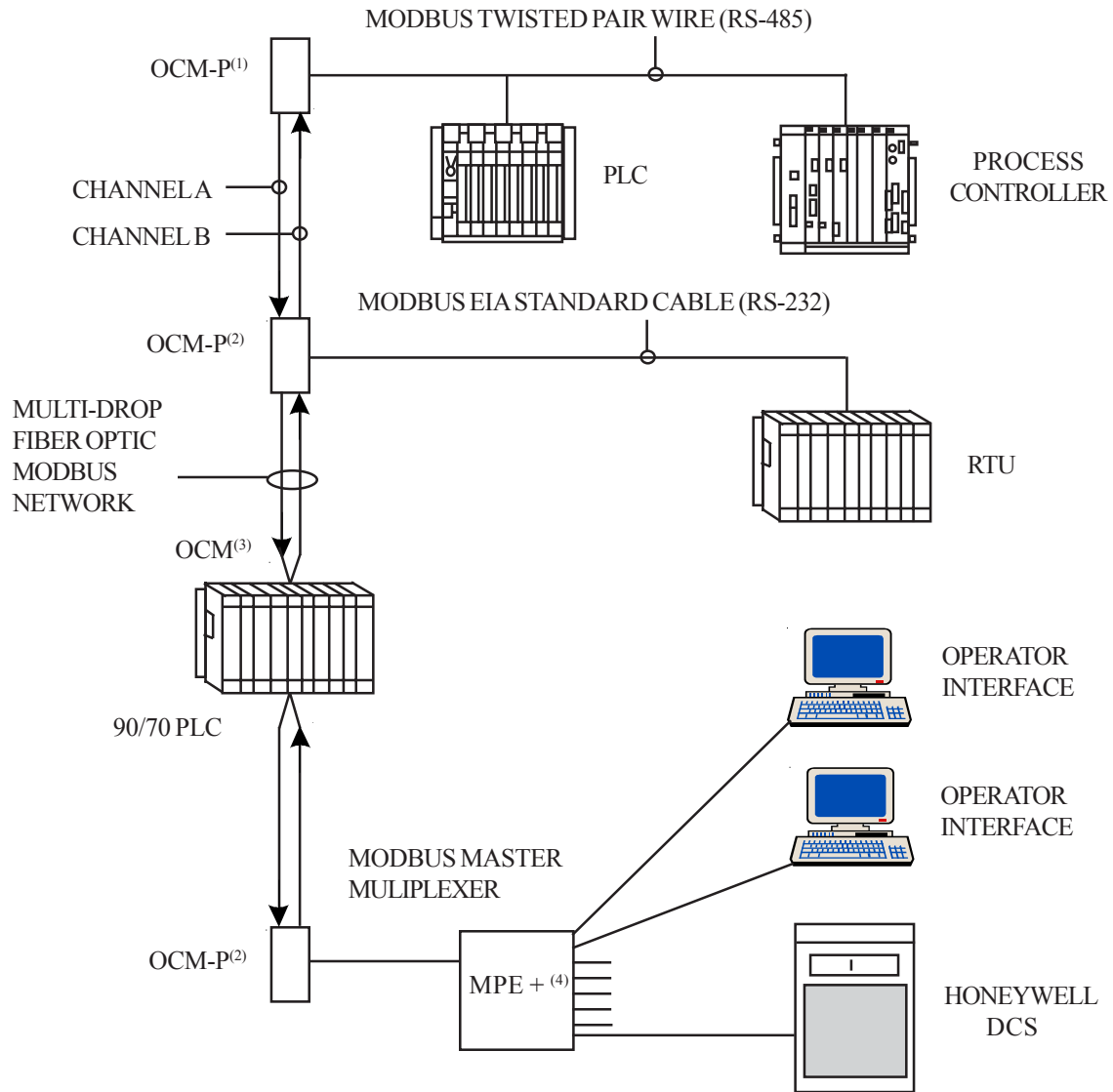

(1) OPTICAL COMMUNICATION MODULE
MODEL # OCM-MOD-85-P-D-ST-ACV-485

(2) OPTICAL COMMUNICATION MODULE
MODEL # OCM-MOD-85-P-D-ST-ACV

(3) OPTICAL COMMUNICATION MODULE
MODEL # OCM-MOD-85-D-ST

(4) MODBUS PORT EXPANDER PLUS
MODEL # MPE + - ACV
(Consult the factory for more information on Phoenix Digital's complete line of Modbus Port Expanders, Network Servers, and Communication Controllers.)

TYPICAL MODBUS OCM and MPE+ INSTALLATION CONFIGURATION

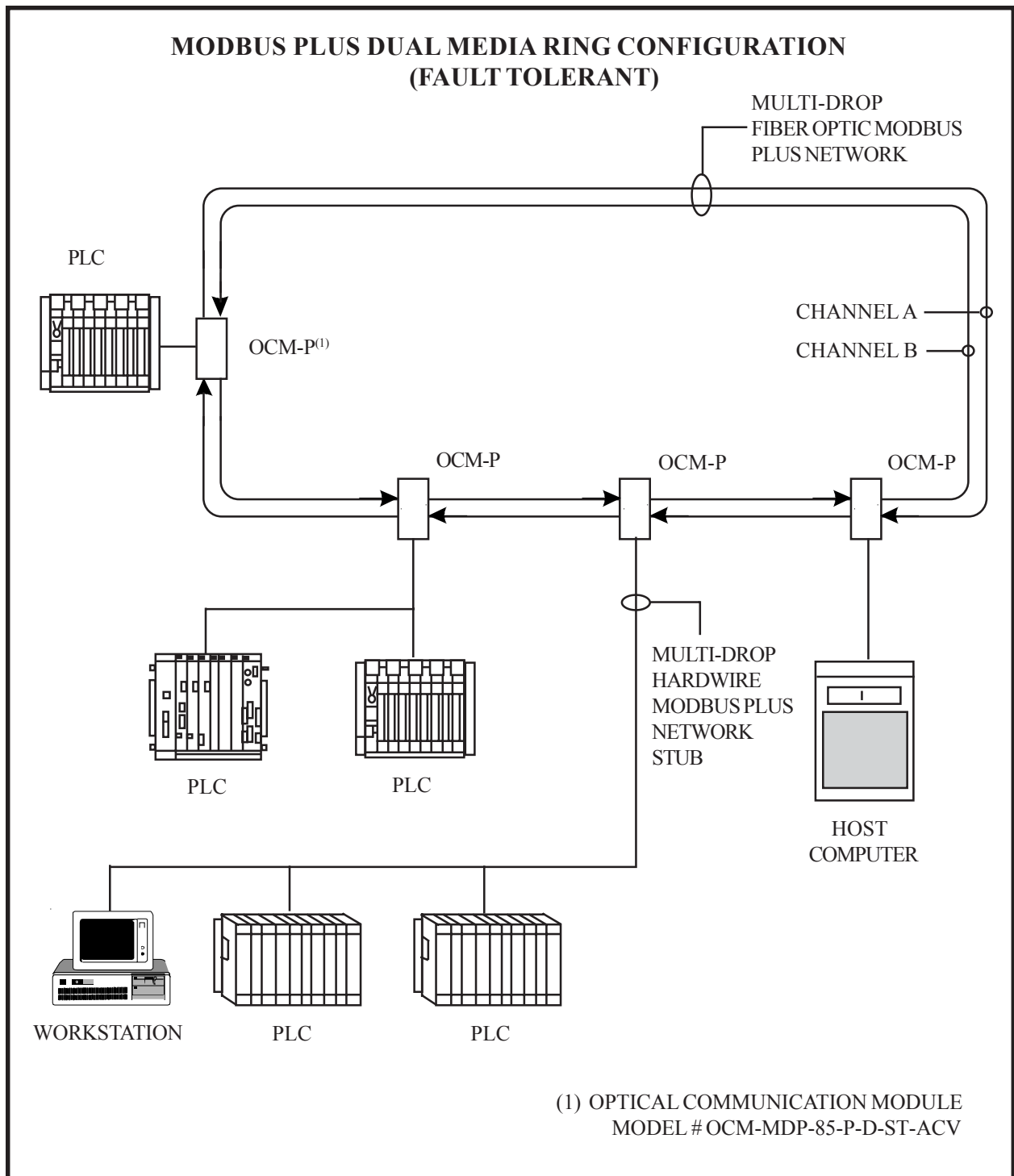

TYPICAL OCM INSTALLATION CONFIGURATION



7560 East Evans Rd., Bldg A
 Scottsdale, AZ 85260
 (480) 483-7393 Phone
 (480) 483-7391 Fax
 email: phxdigital@aol.com
 internet: <http://www.phoenixdigitalcorp.com>

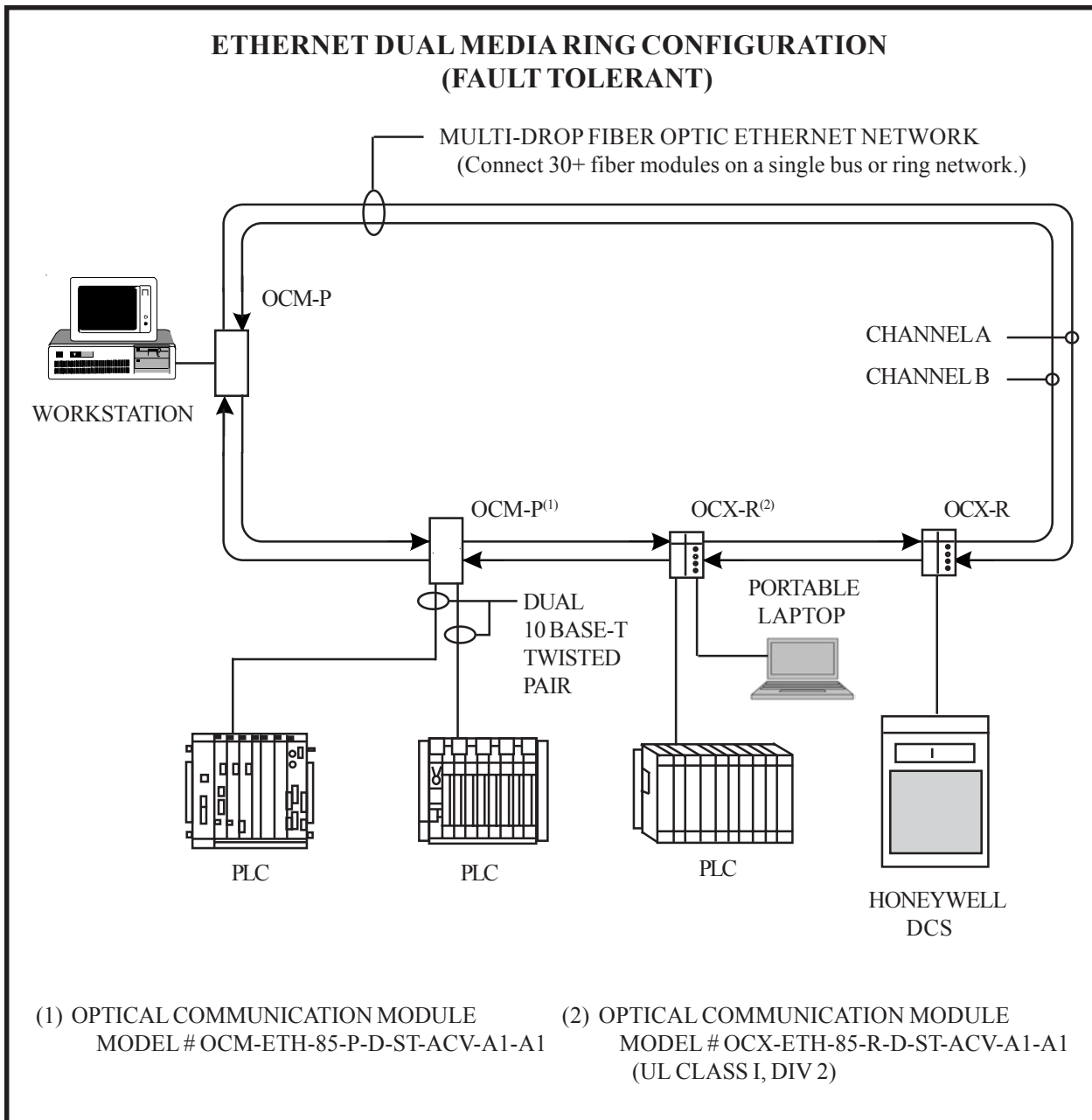

TYPICAL ETHERNET OCM/OCX INSTALLATION CONFIGURATION



7650 East Evans Rd., Bldg. A
 Scottsdale, AZ 85260
 (480) 483-7393 Phone
 (480) 483-7391 Fax
 email: phxdigital@aol.com
 internet: <http://www.phoenixdigitalcorp.com>